

# Vandal Resistant CP Lead Safe™ 1/2 Turn Ceramic Disc Bib Tap Aerated (Cold/Hot/Warm)

## PRODUCT CODES:

- 174.49.27.00

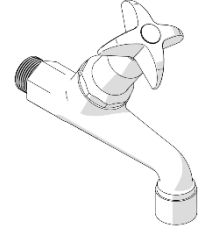

## SPECIFICATIONS

- Chrome plate finish for easy cleaning and durability.
- Simple servicing and readily available parts.
- Vandal resistant handle featuring a locking ring to secure the handle to the spindle which may only be removed using the key provided.
- Supplied with cold, hot and warm identification buttons.
- Lead Safe™ brass construction.\*

**IMPORTANT:** All vandal resistant taps are tested in accordance with AS/NZS 3718 and leave our premises in good working order.

\*Our Lead Safe™ product range is compliant with the Lead Free Requirements of the NCC 2022 Vol. Three, Clause A5G4(2) and NSF/ANSI 372.

\*\*Any flow controller incorporated in the outlet to be tightened to prevent removal by hand. As Per AS3718.

**WARNINGS:** Special attentions to be paid on notes, photos, images, or drawings of assembly steps marked with the warning symbol.



## TECHNICAL DATA

Inlet	G 1/2" - Male	
Outlet	Aerator	
Headwork	Cam Action	
Working Pressure Range (kPa)	Min	50
	Max	500
Working Temperature Range (°C)	Min	5
	Max	65
Nominal Flow Rate (LPM)	7.86	
Finish	Chrome	

**NOTE:** Galvin Engineering continually strives to improve their products. Specifications may change without notice.

## PRE-INSTALLATION

- Before installation, all lines must be flushed.
- Galvin Engineering recommends the installation of strainers and pressure reducing valves (when necessary) to ensure clean consistent supply. Debris or poor water quality could affect the performance of the unit.

**TOOLS REQUIRED**

- Spanner or adjustable crescent
- Thread / sealant tape

**DIMENSIONS**

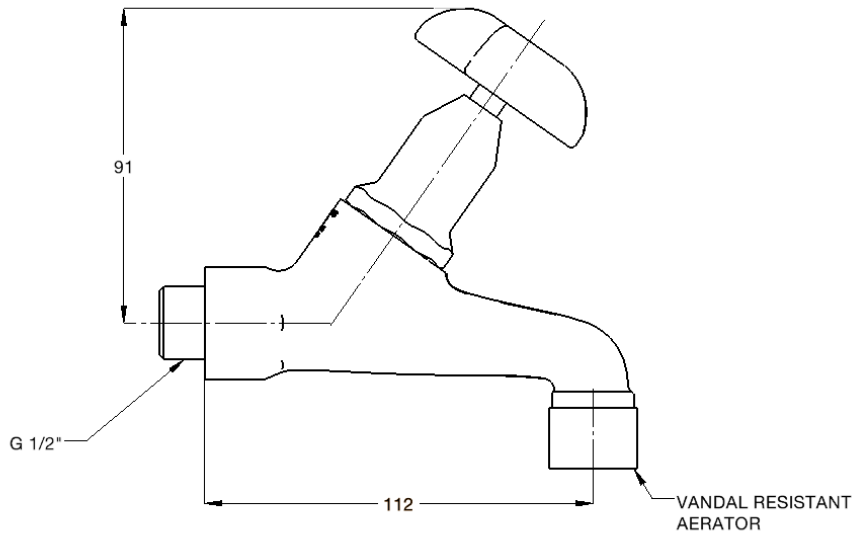

**INSTALLATION**

**INSTALLATION COMPLIANCE:** Galvin Engineering products must be installed in accordance with these installation instructions and in accordance with AS/NZS 3500, the PCA and your local regulatory requirements. Water and/or electrical supply conditions must also comply to the applicable national and/or state standards. Failing to comply with these provisions shall void the product warranty and may affect the performance of the product.

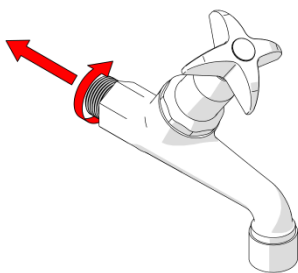

**1. Fit tap assembly**

- When applying thread tape or sealant to the inlet, ensure the opening is not obscured. Failure to do so may restrict or block the flow restrictor, affecting the flow of water.

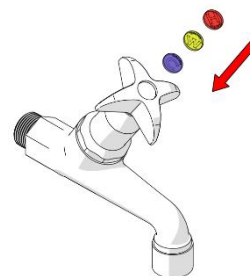

**2. Fit water temperature indicator**

- Once the tap is secure, fit the appropriate water temperature indicator.

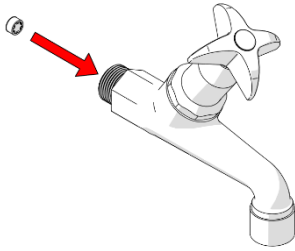

**3. Replace flow restrictor (if required)**

- Major restrictions to the supply pressure (e.g.refrigeration units) may effect the water stream and the flow restrictor may need replacing with a flow restrictor of greater capacity to increase the flow. However, using a different flow restrictor will void the WELS star rating.
- Never operate without a flow restrictor, as this tap will deliver full mains pressure with unrestricted flow.

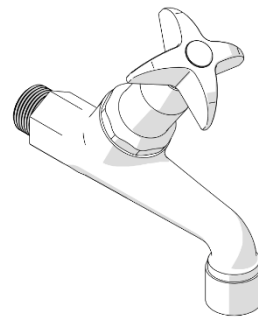

**4. Testing**

- Once fitted, turn on water and check for leaks and correct operation.

**TROUBLESHOOTING**

PROBLEM	CAUSE	RECTIFICATION
Water is not flowing or inconsistent flow.	Blocked flow regulator/ dirt in the cartridge / water supply not on.	Remove flow regulator from inlet and remove debris. Install an inline strainer to stop further blockages. Ensure water supply is turned on.
Continous flow of water.	Top assembly cartridge loose or internally obstructed or damaged.	Remove cartridge, clean with water and re-grease spindle if required.
Rate of flow inadequate.	The flow restrictor may not be satisfactory due to inadequate supply pressure.	Remove flow restrictor and replace with a flow restrictor of different capacity to suit (available from Galvin Engineering).

## WARRANTY

Galvin Engineering products are covered under our Manufacturer's Warranty. Galvin Engineering products must be installed in accordance with the installation instructions and in accordance with AS 3500 and NCC Volume Three, relevant Australian Standards and local authorities applicable to product being installed. Water and electrical supply conditions must also comply to the applicable national and/or state standards, failing to comply with these provisions may void the product warranty and affect performance of the product.

Please visit [www.galvinengineering.com.au](http://www.galvinengineering.com.au) to view the full warranty, our Installation Compliance and Maintenance & Cleaning information as well as any other additional information.